

THE VENTURI AND THE AIRFLOW CONTROL

Let's explain in detail the operation of a motorcycle's carburetor, examining the relationships between the elements which regulate fuel delivery.

Motorcycle carburetors are mainly needle type with the air flow adjusted by means of a sliding valve that, depending on the different versions, can have a cylindrical or flat profile.

Even in vacuum carburetors, also called at constant speed, we find such a valve that works together with the throttle valve actuated

by the driver. We will talk about these carburetors later on due to their peculiar working features.

THE VENTURI

The venturi is one of the elements that define the carburetor, since a basic dimension is the diameter of the venturi itself, generally expressed in mm. The diameter choice is strictly related to the engine

requirements, which must be satisfied.

For motorcycle engines, a separate carburetor feeds each cylinder; therefore the problem of flow distribution from a single carburetor to different cylinders is avoided.

From a numerical point of view the critical dimensions are selected



The venturi of the modern motorcycle carburetor is carefully developed to reduce disturbances in the flow around the throttle valve and its seat.

On the left-hand side, we see the venturi fitted on a Dell'Orto VHSD carburetor with two thin slits where the guillotine runs to adjust the airflow.

Below, left hand side the section of a VHSB carburetor where the reduced thickness of the flat throttle is emphasized. On the right is the cylindrical valve of a carburetor series PH, showing a dimension in the flow direction, higher than in the first case. In both drawings we can see, under the venturis, the passages which lead to the idle and progression circuits, which we will discuss later in this article.

according to constructive practice and from the experience accumulated on a wide range of motorcycles and engine types. The diameter determination is then made through tests on the engine. For instance, small two-stroke en-

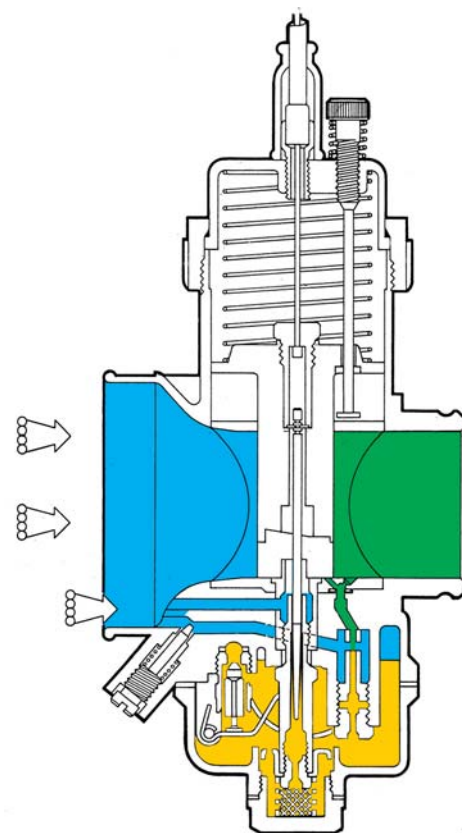
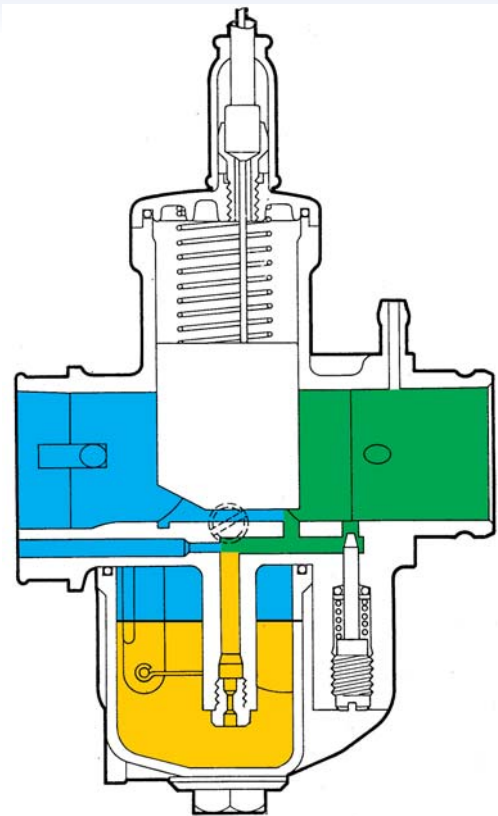

gines used in cycles and scooters are equipped with carburetors having a venturi with a diameter from 12 to 14mm. On 125cm³ displacement two stroke engines used in competition, we use venturis with diameters which can vary from 36 up to 40 mm and over, as is common on powerful rotary valve units used in racing. When performance is the main consideration, the venturi diameter determines the resistance that the aspiration system (the carburetor's venturi is part of this system) offers to the aspirated flow. Large diameter venturis obviously introduce a lower resistance than we usually have with smaller diameter venturis, therefore in order to improve the efficiency of this component, inserts inside the venturi itself are used, which eliminate steps and shape variations, while keeping the diameter value.

The inserted venturis of Dell'Orto VHSB series carburetors are shown in the illustrations.

On the contrary, a venturi with reduced diameter results in higher air speed at an equal flow induc-

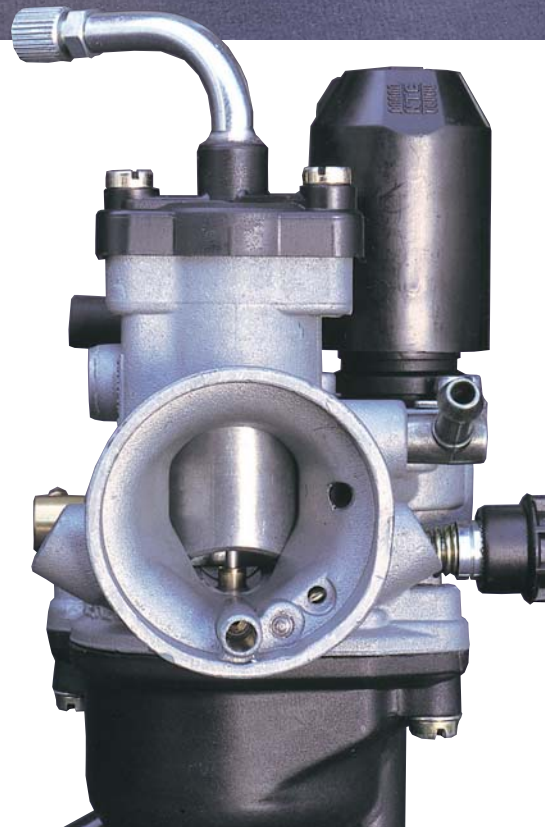
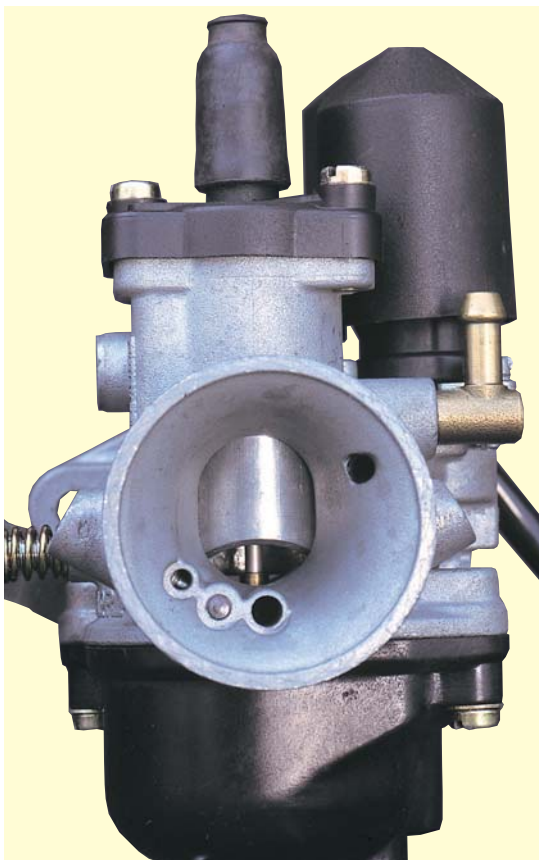
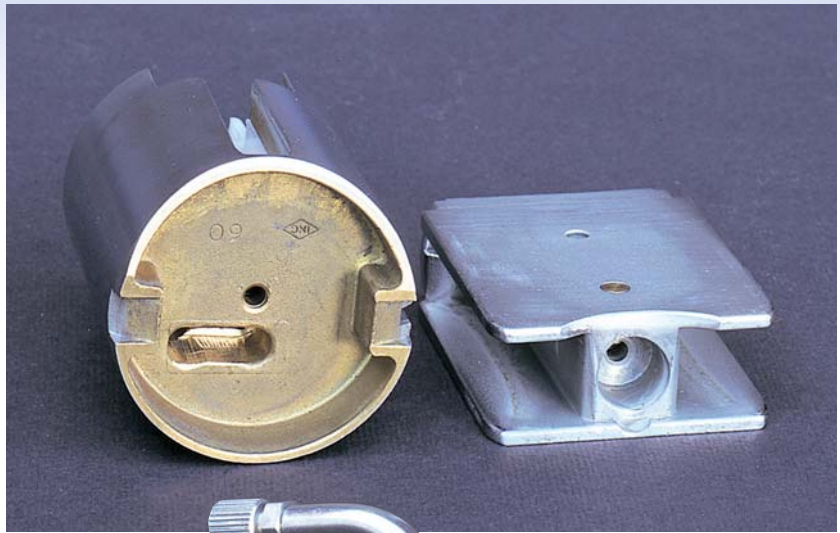

Shown above are two different shapes of the venturi's opening. On the left we have the classic oval section while on the right the one called "badge (shield)" which shows a smaller area portion on the lower side, close to the small fuel ports that results in better modulation as required by some engine types.

Below, a comparison between a round piston throttle valve and a plane valve, also called guillotine. In the center we have the guiding hole for the conical needle.

Above, on the left: valves often have a hardened surface with chrome plating in order to assure high resistance to wear. The shape of both edges is very important to assure there is no leakage when the valve is closed. On the right is a valve introduced in the insert-venturi that is assembled in the carburetor's body (Dell'Orto VHSB). Below, the valve and spring assembly of a competition Dell'Orto VHSD carburetor. The spring is of small dimensions, but sufficient to shut off the airflow, thanks to the low friction of the sliding guillotine.

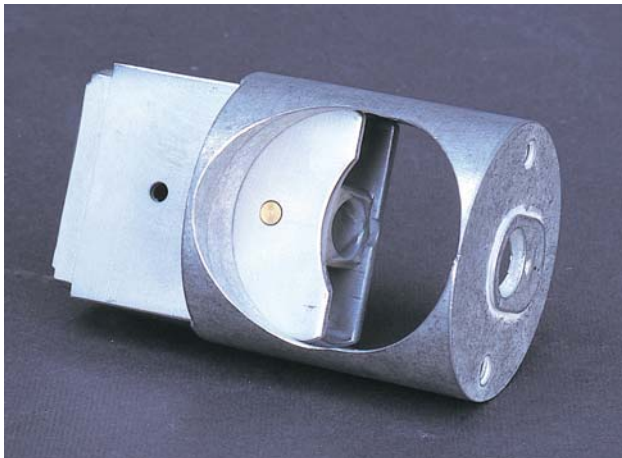
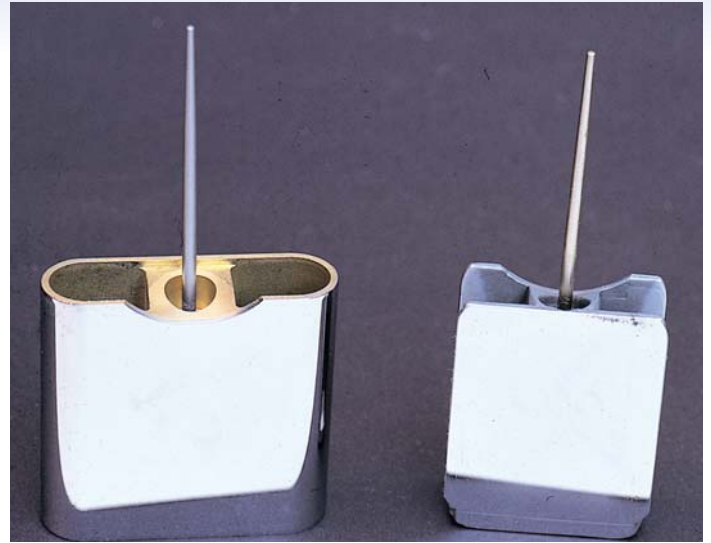

ted by the engine and, therefore, results in a higher vacuum signal on the nozzles which deliver the fuel.

In some conditions and for engines that have to work over a wide range of r.p.m., such a feature can become very important, with less consideration to the need for lower resistance.

On this matter we can assert that the power loss introduced by the carburetor depends, in addition to the diameter of its venturi, on its profile in the direction of the airflow.

Beyond the configuration of the throttle valve area, the connections with the air intake and the area downstream of the venturi, where the carburetor connects with the aspiration channel, are very important.

THE SHAPE OF THE VENTURI SECTION

Once the area is determined, according to the supply requirements of the engine, there are design choices to be made on the shape of the venturi section.

For competition engines or engines which have to offer high performance without any particular concern regarding other operating modes, the most favorable section with regard to power loss



The throttle valve of "needle" carburetors has a chamfered edge (measured in tenths of mm: for example, .30) which influences the carburation at small throttle openings. A valve with low chamfer (as above) enriches the mixture up to 1/4 throttle, while if the carburation is too rich, we can use a valve with a higher chamfer (as below).

The influence of this calibration element is mainly in transient operation at small throttle openings and even limited changes (i.e. from .30 to .40) may strongly influence the delivered mixture.

is the round section, since it has the minimum perimeter (at equal areas) to resist inducted flow. For engines which have to provide a smooth modulation of power, we use generally carburetors with a venturi having an extended shape section, called "oval" or even a more complex shape such as the one Dell'Orto engineers called "badge (shield)" and which represents an evolution of the concept of the oval section venturi. As we have seen, a small diameter venturi improves the engine's responsiveness, since it keeps the flow velocity high. An oval venturi presents a smaller section, because it has a reduced diameter when the throttle valve is lifted slightly.

At small openings, then, the carburetor behaves as it had a reduced diameter. This provides a good solution to transient operation and wide power range, and gives a good relationship of proportionality between the driver's action and response in terms of delivery from the carburetor. When the throttle opening increases, the shape of the venturi section recovers the area necessary to aspirate the flow without introducing any high fluidynamic resistance. The badge (shield) venturi has a triangular shape at small throttle openings, and therefore in this region, the opening area is very reduced, to enhance the features of



response which are necessary on some kinds of engines with automatic transmissions.

THROTTLE VALVE

In traditional non-vacuum carburetors, this is the adjustment component connected to the accelerator by means of a flexible cable.

This valve slides transversely to the venturi determining the effective area of the flow passage.

In different carburetor models (such as Dell'Orto series PH, where P means "Piston" referring to the valve, and H means "Horizontal" referring to the channel orientation), the valve is a cylindrical element which slides with

very little clearance in a seat, machined into the carburetor's body. In other versions (Dell'Orto series VH, where V means "valve") the element is plane, with driving flyers or rounded edges developed to reduce air leakage, as for example in Dell'Orto VHSD.

For carburetors used in 4 stroke engines, the vacuum in aspiration, at closed position, can reach extremely high values and keep the valve pressed against its seat.

In order to eliminate wear (and therefore leakage) and sticking, these components undergo surface treatments which improve the hardness of the material and operating smoothness, similar to chromed brass valves.

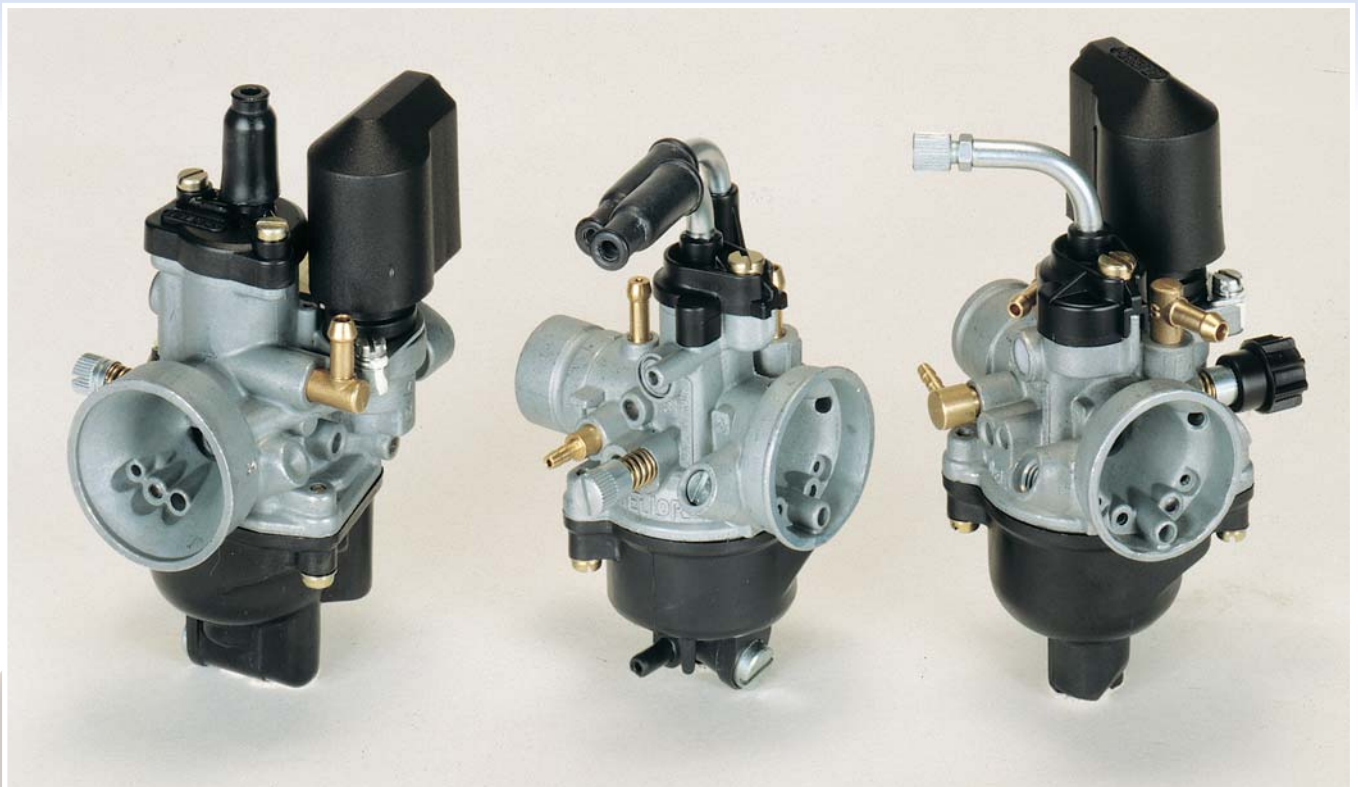

Together with these designs, some slightly stiff return springs are used, in order to assure a positive return to the closed valve position.

However, since the stiffness of the spring determines the opening effort from the driver, it's a good rule to choose valves which slide more smoothly before increasing the return spring force.

The valves called "plane" reduce the turbulence affecting the air flow that goes under the valve itself since this design provides a shorter impediment in the direction of the flow itself.

Even for this kind of valve we must carefully understand all the issues related to sealing at the closed condition, providing surfaces with chrome plating to reduce wear.

The advantages we gain in terms of deflection of the flow path with a reduced width valve are however counterbalanced by the need to solve the problem of location of the progression holes.

These holes are needed to deliver fuel when the throttle opening changes, during the progressive-transition from operation of the idle circuit to the main one and

vice-versa.

These holes are machined downstream the main atomizer, but in order to work, as we will see later on, they have to be below the throttle valve edge.

If the valve is very tight, these holes will obviously be very close to the main atomizer (also located under the valve) making the design approach more complex.

Once it has been solved, however, this design will assure the best functionality.

Some of the carburetors Dell'Orto has developed for modern, small displacement motorcycles.

In this case, some tricks have been in this case adopted: elaborate shape venturis and automatic starting circuit, which provide for the best operation of the engine under all conditions.